

# DIESEL ENGINE-GENERATOR SET

## AIR CHARGE-AIR COOLING

400 kVA / 50 Hz / Standby (Fuel-Optimized)  
380 - 415V

(Reference DP365D5S-Fuel Optimized and DP365D5S-Exhaust Optimized for Prime Rating Technical Data)



### SYSTEM RATINGS

Standby	DS400D5SVA	DS400D5SFA	DS400D5SEA
Voltage (L-L)	380V	400V	415V
Phase	3	3	3
PF	0.8	0.8	0.8
Hz	50	50	50
kW	320	320	320
kVA	400	400	400
AMPS	608	577	556
skVA@30%			
Voltage Dip	660	730	820
Generator Model	433CSL6220	433CSL6220	572RSL4025
Temp Rise	150 °C/40 °C	150 °C/40 °C	150 °C/40 °C
Connection	12 LEAD HI WYE	12 LEAD HI WYE	4 LEAD WYE

### CERTIFICATIONS AND STANDARDS

// **Engine-generator set is designed and manufactured in facilities certified to standards ISO 9001:2008 and ISO 14001:2004**

// **Performance Assurance Certification (PAC)**

- Engine-Generator Set Tested to ISO 8528-5 for Transient Response
- Verified product design, quality and performance integrity
- All engine systems are prototype and factory tested

// **Power Rating**

- Accepts Rated Load in One Step Per NFPA 110
- Permissible average power output during 24 hours of operation is approved up to 85%.



For More Information:  
(866) 787-3271  
Sales@PTSdcs.com

## STANDARD FEATURES\*

- // MTU Onsite Energy is a single source supplier
- // Global Product Support
- // 2 Year Standard Warranty
- // 8V1600 Diesel Engine
  - 14.0 Liter Displacement
  - Common Rail Fuel Injection
  - 4-Cycle
- // Engine-generator resilient mounted
- // Complete Range of Accessories
- // Generator
  - Brushless, Rotating Field Generator
  - 2/3 Pitch Windings
  - 300% Short Circuit Capability with PMG
    - o PMG Standard for 570 frame and larger
    - o PMG Optional for 430 frame and smaller
- // Digital Control Panel(s)
  - UL Recognized, CSA Certified, NFPA 110
  - Complete System Metering
  - LCD Display
- // Cooling System
  - Integral Set-Mounted
  - Engine Driven Fan

## STANDARD EQUIPMENT\*

### // Engine

Air Cleaners  
 Oil Pump  
 Oil Drain Extension & S/O Valve  
 Full Flow Oil Filters  
 Closed Crankcase Ventilation  
 Jacket Water Pump  
 Thermostats  
 Blower Fan & Fan Drive  
 Radiator - Unit Mounted  
 Electric Starting Motor - 24V  
 Governor - Electronic Isochronous  
 Base - Formed Steel  
 SAE Flywheel & Bell Housing  
 Charging Alternator - 24V  
 Battery Box & Cables  
 Flexible Fuel Connectors  
 Flexible Exhaust Connection

### // Generator

NEMA MG1, IEEE and ANSI standards compliance for temperature rise and motor starting  
 Sustained short circuit current of up to 300% of the rated current for up to 10 seconds  
 Self-Ventilated and Drip-Proof  
 Superior Voltage Waveform  
 Digital, Solid State, Volts-per-Hertz Regulator  
 No Load to Full Load Regulation

Brushless Alternator with Brushless Pilot Exciter  
 4 Pole, Rotating Field  
 150 °C Maximum Standby Temperature Rise  
 1 Bearing, Sealed  
 Flexible Coupling  
 Full Amortisseur Windings  
 125% Rotor Balancing  
 3-Phase Voltage Sensing  
 ±0.25% Voltage Regulation  
 100% of Rated Load - One Step  
 3% Maximum Harmonic Content

### // Digital Control Panel(s)

Digital Metering  
 Engine Parameters  
 Generator Protection Functions  
 Engine Protection  
 CAN Bus ECU Communications  
 Windows-Based Software  
 Multilingual Capability  
 Remote Communications to RDP-110 Remote Annunciator  
 16 Programmable Contact Inputs  
 Up to 11 Contact Outputs  
 UL Recognized, CSA Certified, CE Approved  
 Event Recording  
 IP 54 Front Panel Rating with Integrated Gasket  
 NFPA110 Compatible

\* Represents standard product only. Consult Factory/MTU Onsite Energy Distributor for additional configurations.

## APPLICATION DATA

## // Engine

Manufacturer	MTU
Model	8V1600G70F
Type	4-Cycle
Arrangement	8-V
Displacement: L (Cu In)	14 (854)
Bore: cm (in)	12.2 (4.8)
Stroke: cm (in)	15 (5.9)
Compression Ratio	17.5:1
Rated RPM	1,500
Engine Governor	Electronic Isochronous (ADEC)
Max Power: kWm (bhp)	358 (480)
Speed Regulation	±0.25%
Air Cleaner	Dry

## // Liquid Capacity (Lubrication)

Total Oil System: L (gal)	46 (12.2)
Engine Jacket Water Capacity: L (gal)	50 (13.2)
System Coolant Capacity: L (gal)	80.3 (21.2)

## // Electrical

Electric Volts DC	24
Cold Cranking Amps Under -17.8 °C (0 °F)	1,000

## // Fuel System

Fuel Supply Connection Size	#10 JIC 37° Female M20 x 1.5 Male Adapter Provided
Fuel Return Connection Size	#6 JIC 37° Female M14 x 1.5 Male Adapter Provided
Maximum Fuel Lift: m (ft)	5 (16)
Recommended Fuel	Diesel #2
Total Fuel Flow: L/hr (gal/hr)	342 (90.4)

## // Fuel Consumption

	STANDBY
At 100% of Power Rating: L/hr (gal/hr)	81 (21.4)
At 75% of Power Rating: L/hr (gal/hr)	61 (16.2)
At 50% of Power Rating: L/hr (gal/hr)	45 (12)

## // Cooling - Radiator System

	STANDBY
Ambient Capacity of Radiator: °C (°F)	50 (122)
Max. Restriction of Cooling Air, Intake, and Discharge Side of Rad.: kPa (in. H <sub>2</sub> O)	0.125 (0.5)
Water Pump Capacity: L/min (gpm)	362 (95)
Heat Rejection to Coolant: kW (BTUM)	180 (10,237)
Heat Rejection to After Cooler: kW (BTUM)	60 (3,412)
Heat Radiated to Ambient: kW (BTUM)	40.8 (2,320)

## // Air Requirements

	STANDBY
Aspirating: *m <sup>3</sup> /min (SCFM)	23.4 (827)
Air Flow Required for Rad.	
Cooled Unit: *m <sup>3</sup> /min (SCFM)	510 (18,010)
Remote Cooled Applications;	
Air Flow Required for Dissipation of Radiated Gen-set Heat for a Max of 25 °F Rise: *m <sup>3</sup> /min (SCFM)	148.2 (5,233)

\* Air density = 1.184 kg/m<sup>3</sup> (0.0739 lbm/ft<sup>3</sup>)

## // Exhaust System

	STANDBY
Gas Temp. (Stack): °C (°F)	476 (889)
Gas Volume at Stack	
Temp: m <sup>3</sup> /min (CFM)	66 (2,331)
Maximum Allowable	
Back Pressure: kPa (in. H <sub>2</sub> O)	15 (60.2)

## WEIGHTS AND DIMENSIONS

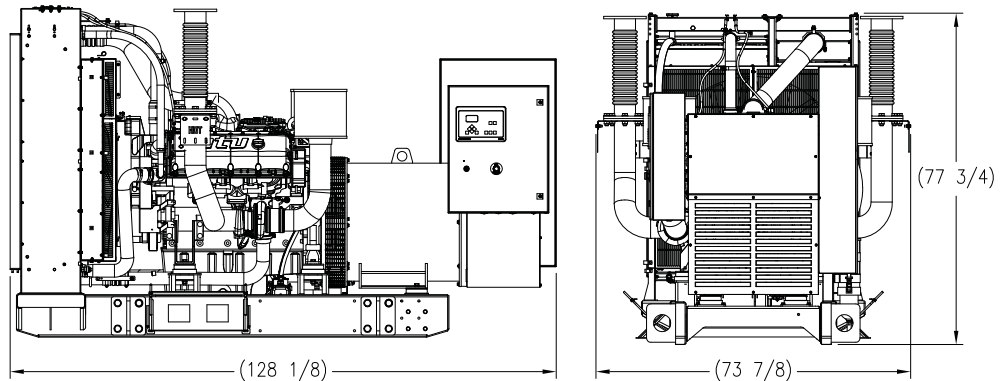

Drawing above for illustration purposes only, based on standard open power 400 volt engine-generator set. Lengths may vary with other voltages. Do not use for installation design. See website for unit specific template drawings.

<b>System</b> Open Power Unit (OPU)	<b>Dimensions (L x W x H)</b> 3,255 x 1,877 x 1,975 mm (128.13 x 73.88x 77.75 in)	<b>Weight (dry/less tank)</b> 3,992 kg (8,800 lb)
--	--	--

Weights and dimensions are based on open power units and are estimates only. Consult the factory for accurate weights and dimensions for your specific engine-generator set.

## SOUND DATA

<b>Unit Type</b> Level 0: Open Power Unit (dBA)	<b>Standby Full Load</b> C/F
--	---------------------------------

Sound data is provided at 7 m (23 ft). Engine-generator set tested in accordance with ISO 8528-10 and with infinite exhaust.

## EMISSIONS DATA

<b>NO<sub>x</sub> + NMHC</b> C/F	<b>CO</b> C/F	<b>PM</b> C/F
-------------------------------------	------------------	------------------

## RATING DEFINITIONS AND CONDITIONS

- // Standby ratings apply to installations served by a reliable utility source. The standby rating is applicable to varying loads for the duration of a power outage. No overload capability for this rating. Ratings are in accordance with ISO 8528-1, ISO 3046-1, BS 5514, AS 2789, and DIN 6271.
- // Deration Factor:
  - Altitude:** Consult your local MTU Onsite Energy Power Generation Distributor for altitude derations.
  - Temperature:** Consult your local MTU Onsite Energy Power Generation Distributor for temperature derations.



**For More Information:**  
(866) 787-3271  
Sales@PTSdcs.com

**DATA CENTER SOLUTIONS**

Materials and specifications subject to change without notice.

C/F = Consult Factory/MTU Onsite Energy Distributor